

Dimensioni Dimensions

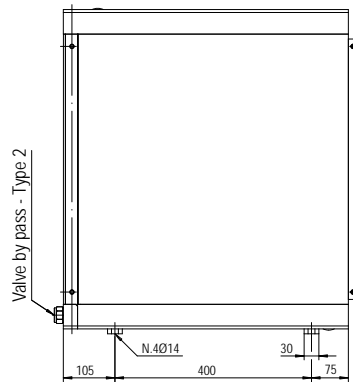

P/N 2W5001###
P/N 2W5003###

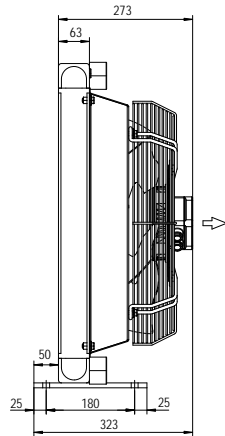
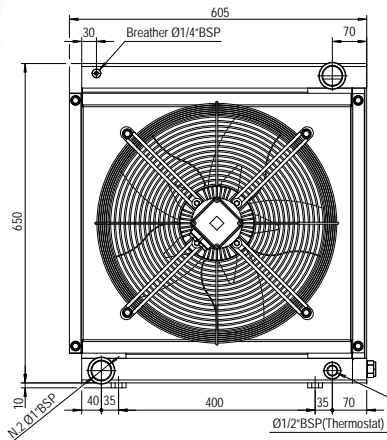
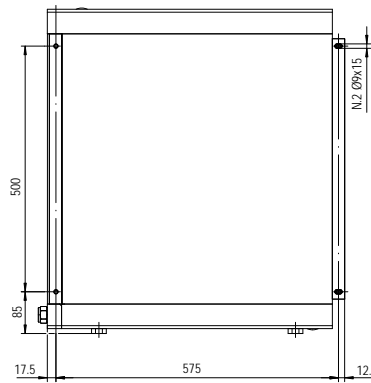
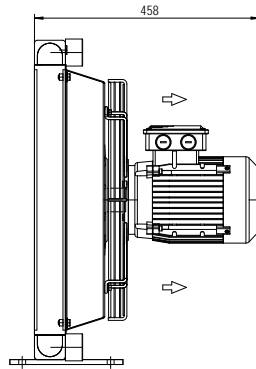
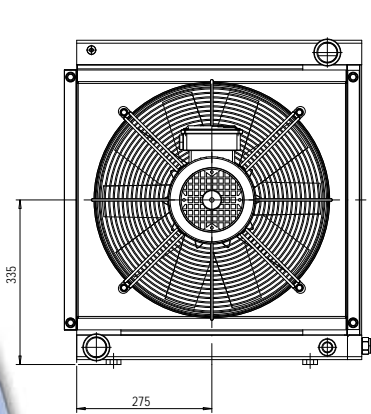

P/N 2W5004###

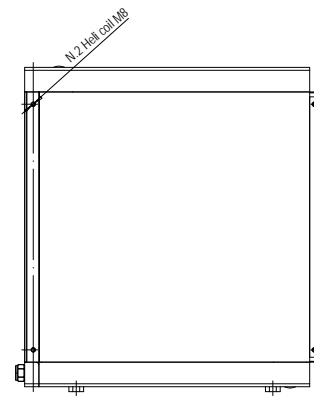
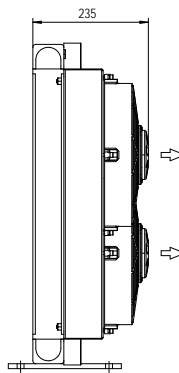
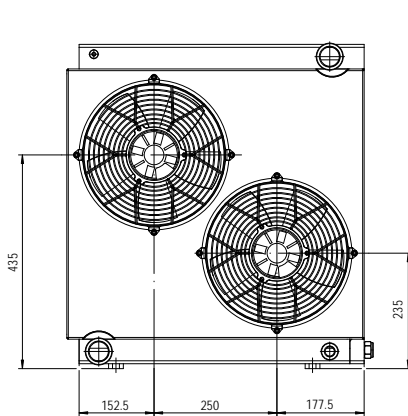

P/N 2W5012###
P/N 2W5024###

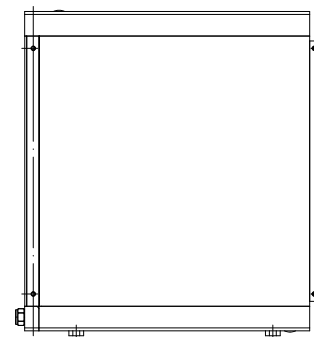
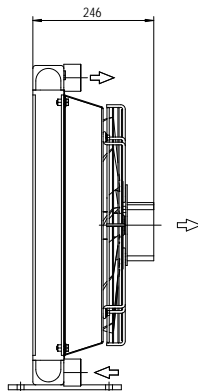
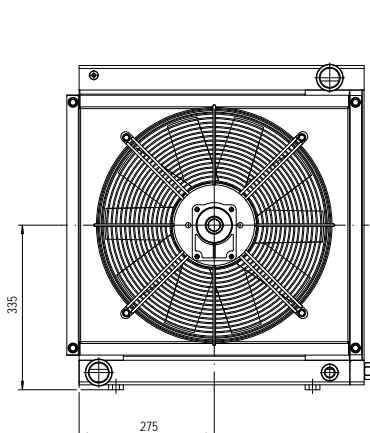

P/N 2W5056###

Le dimensioni di ingombro e le caratteristiche tecniche non sono impegnative
Over-all dimensions and technical characteristic are not binding

MG2050KBV

Dati tecnici Technical Data



P/N	V	Hz	kW	A	rpm	ø Fan	dB(A)	(m³/h)	IP	lt	Kg
2W5003 ###	230-400 AC	50/60	0,43	0,9	1340	450	76	5000	54	5	27
2W5004 ###	230-400 B14 AC	50/60	0,75	1,88	1450	450	79	5200	55		30
2W5012 ###	12 DC	/	0,15	9,5	3100	280	76	2000	68		24
2W5024 ###	24 DC	/	0,15	5,6	3100	280	79	2000	68		24
2W5056 ###	Prepared for Gr.2 hydraulic monitor					450			/		23

Contattare EMMEGI Contact EMMEGI

Diagramma rendimento Performance diagram

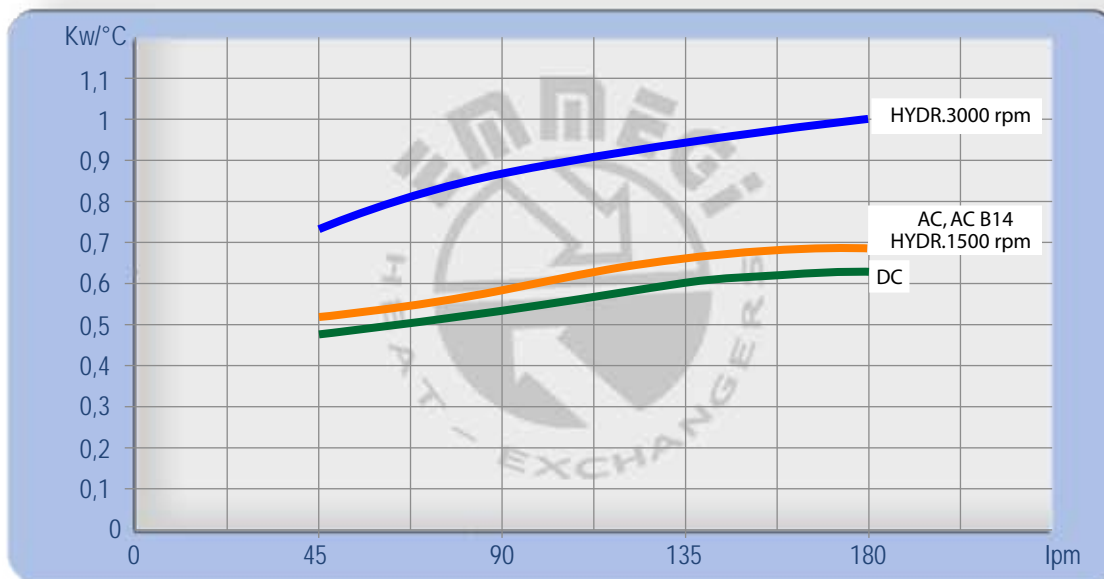

Perdite di carico Pressure drop (ISO VG 32)

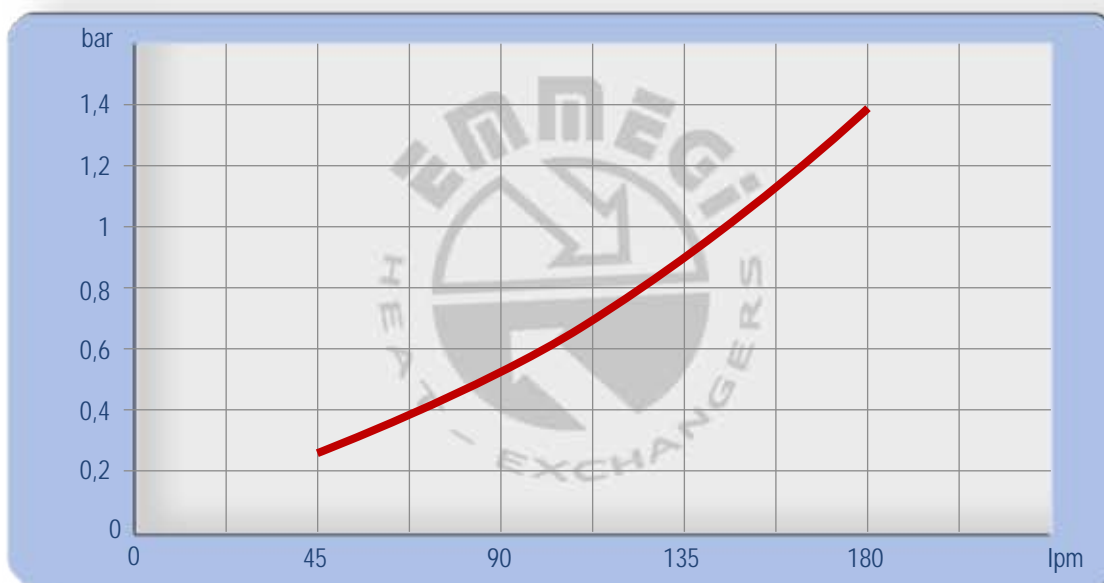

Fattore di correzione - F -(perdite di carico) Correction factor - F - (Pressure drop)

cst	10	15	20	30	40	50	60	80	100	200	300
F	0,5	0,65	0,77	1	1,2	1,4	1,6	1,9	2,1	3,3	4,3

MG2050KBV