

## 4.1 Technical features

<b>Max working pressure PS:</b>	360 bar
<b>Test pressure PT:</b>	PS x 1,43 bar
<b>Temperature range min. and max TS:</b>	-40°C ÷ +120°C (subject to restrictions due to bladder material)
<b>Nominal capacities:</b>	0,2 ÷ 55 litres

## 4.2 Construction features

### THE STANDARD VERSION (AS) INCLUDES:

- Shell in hardened and tempered carbon steel, sandblasted and painted outside with a coat of rust inhibitor.
- Valves in phosphated carbon steel.
- Female ISO 228 G threaded fluid port connection.
- Bladder and gaskets in standard nitrile rubber (P).
- Testing and certification according to directive 97/23/EC.
- Preloading with nitrogen at **30 bar** (other values available if specified in order).

**N.B.** Technical features of **AS** standard version are also valid for **AST** and **ASL** versions except for the structure of gas side valve (see pages 36 and 37).

### ON REQUEST the accumulator can be supplied with the following features:

- SHELL AND VALVES PROTECTED with a chemical coating of nickel (25 microns thick. Specify other thickness if required).
- SHELL AND VALVES IN STAINLESS STEEL  
**0.2 lts.** capacity: max working pressure **210 bar** and **360 bar**.  
**0.7-1-1.5-3 lts.** capacities: max working pressure **150 bar**.  
**5 lts.** capacity: max working pressure **120 bar**.  
**10-55 lts.** capacities: max working pressure **100 bar**.  
 For other pressure values contact our Technical Department.
- BLADDER IN BUTYL, NEOPRENE, ETHYLENE-PROPYLENE, HYDROGENATED NITRILE, NITRILE FOR LOW TEMPERATURES (-40°C), NITRILE FOR HYDROCARBONS, EPICHLOROHYDRIN FOR FOODSTUFFS.
- WORKING PRESSURE PS = 550 BAR for capacities 0,2 and 0,7 litres in carbon steel.
- SAE 3000 or SAE 6000 FLUID PORT CONNECTION (see page 24).
- NPT, SAE or METRIC THREADED FLUID PORT CONNECTION.
- ADAPTER R with ISO 228 thread for the diameters indicated in the table, with other threads to be specified or blind.
- FLUID PORT FLANGED CONNECTION (specify PN and DN and flange standards. For order code see page 24)<sup>1)</sup>.
- GAS SIDE FLANGED CONNECTION for special applications<sup>1)</sup>.
- SAFETY VALVE gas side or liquid side or only with the adapter for this valve (see pages 26-27)<sup>1)</sup>.
- SPECIAL ANTI-PULSATION CONNECTION liquid side (see page 25)<sup>1)</sup>.
- TESTINGS AND CERTIFICATIONS DIFFERENT FROM EC (Ask for availability).

1) Specify features separately.

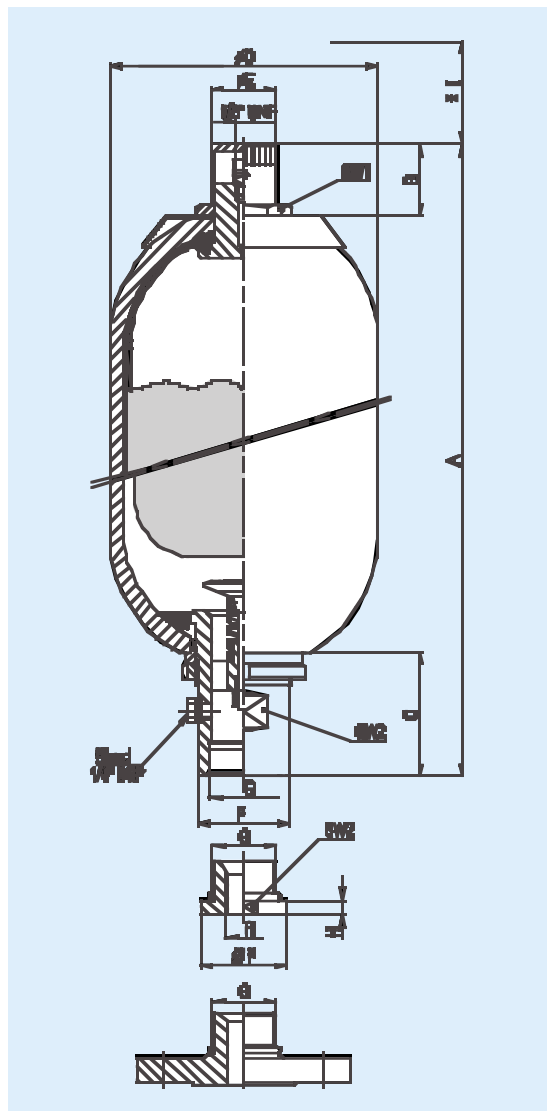

## 4.3 Dimensions 2)

Type	Max work. pressure (bar)	Gas volume (Litres)	Dry weight (kg)	Fluid port connection		A	B	C	øD	øE	øF	H	I*	SW 1	SW 2	
				G BSP ISO228	R BSP ISO228											
<b>AS 0,2</b>	360-550	0,2	1,7	1/2"	—	250 ± 2	22	40	53 + <sub>0</sub> <sup>1</sup>	20	26	—		24	23	
<b>AS 0,7</b>	360-550	0,65	4,2	3/4"	0=blind 3/8" 1/2"	280 ± 3	47	52	90 ± 1	25	36	—	—	—	—	
<b>AS 1</b>	360	1	5,2			295 ± 5										32
<b>AS 1,5</b>	360	1,5	6,3			355 ± 5										
<b>AS 3</b>	360	2,95	11	1 1/4"	0=blind 3/8" - 1/2" - 3/4"	553 ± 8	65	114 ± 1	25	53	—	—	—	—		
<b>AS 5</b>	360	5	15			458 ± 10									70	
<b>AS 10</b>	360	9,1	33	2"	0=blind 3/8" 1/2" 3/4" 1" 1 1/4" 1 1/2"	568 ± 15	60	101	224 ± 2	55	77	11	140	70		70
<b>AS 15</b>	360	14,5	43			718 ± 15										
<b>AS 20</b>	360	18,2	48			873 ± 15										
<b>AS 25</b>	360	23,5	59			1043 ± 15										
<b>AS 35</b>	360	33,5	78			1392 ± 20										
<b>AS 55</b>	360	50	108			1910 ± 20										

\* I = Overall dimensions of pre-loading unit.

2) = Data related to standard version in carbon steel PS = 360 bar.

Subject to change

## 4.4 Components and spare parts

Table 4.4.1 provides a list of accumulator components and, for each model, the part number to be used when ordering spare parts: **THIS NUMBER IS VALID FOR STANDARD VERSIONS ONLY.**

For all versions differing from standard it is necessary to give the **manufacturer's serial number and the material.**

The bladder must be ordered according to the instructions provided on Page 37 or giving the accumulator identification code or manufacturer's serial number.

**Capacities 0.7÷55 litres**

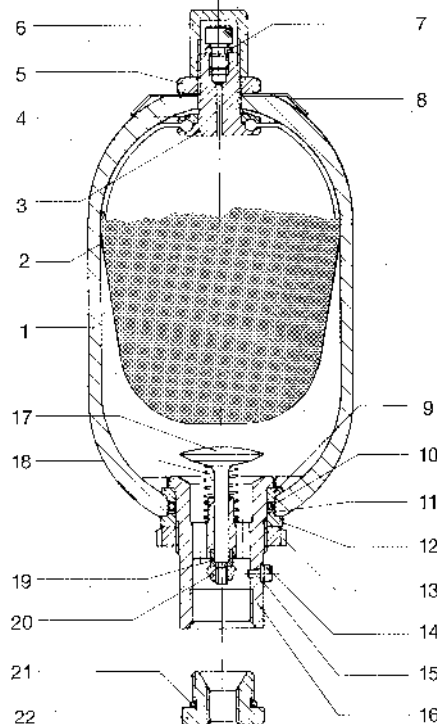

**Capacity 0.2 litres**

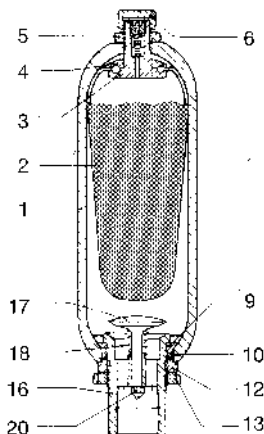

### 4.4.1 Spare parts list and part number

Item	Description	Pcs.	Models					AS 10-15-20 25-35-55
			AS 0,2	AS 0,7	AS 1 - 1,5	AS 3	AS 5	
1	Accumulator shell	1	Not supplied as spare part					
2	Bladder	1	See detailed designation on Pages 36-37					
3	Gas valve body	1	2001	10107		10202	10333	
4	Rubber-coated washer	1	10024	10104	10106	10205	10334	
5	Gas valve locknut	1	10023	10109			10302	
6	Protection cap	1	10337	10103			10301	
7	Gas-fill valve	1	–	2072				
8	Name plate	1	–	10300-A	10300-B		10300-C	10300-D
9	Retaining ring	1	10035	10123	10127	10146	10222	10317
10	“O” ring	1	OR4112	OR4150		OR159	OR6212	OR181
11	Supporting ring	1	10038	10133		10150	10227	10320
12	Space ring	1	10037	10120		10145	10223	10319
13	Fluid port ring nut	1	10039	10122		10217		10321
14	Bleed screw	1	–	10128				10316-A
15	Seal ring	1	–	10129				10336-A
16	Fluid port body	1	10031	10115		10144		10311
17	Poppet	1	10028	10111		10221		10310
18	Spring	1	10029	10112		10149		10322
19	Brake bushing	1	–	10113		10226		10314
20	Selflocking nut	1	10033	10116		10211		10315
21	Adapter “O” ring	1	–	OR2093		OR3150		OR3218
22	Adapter	1	–	10131/Ø thread		10233/Ø thread		10323/Ø thread
Gas valve assembly (parts 3-4-5-6-7)		1	2002	2021	2022		2042	2062
Fluid port assembly (parts 9 ÷20)		1	2004	2023	2024	2025	2044	2064
Gasket sets		1	2010 { OR2050 10341 10342 OR4112 10038	2030 { OR2050 10341 10342 OR4150 10133 10129 OR2093	2031 { OR2050 10341 10342 OR159 10149 10129 OR3150	2050 { OR2050 10341 10342 OR6212 10227 10129 OR3150	2080 { OR2050 10341 10342 OR181 10320 10336 OR3218	