

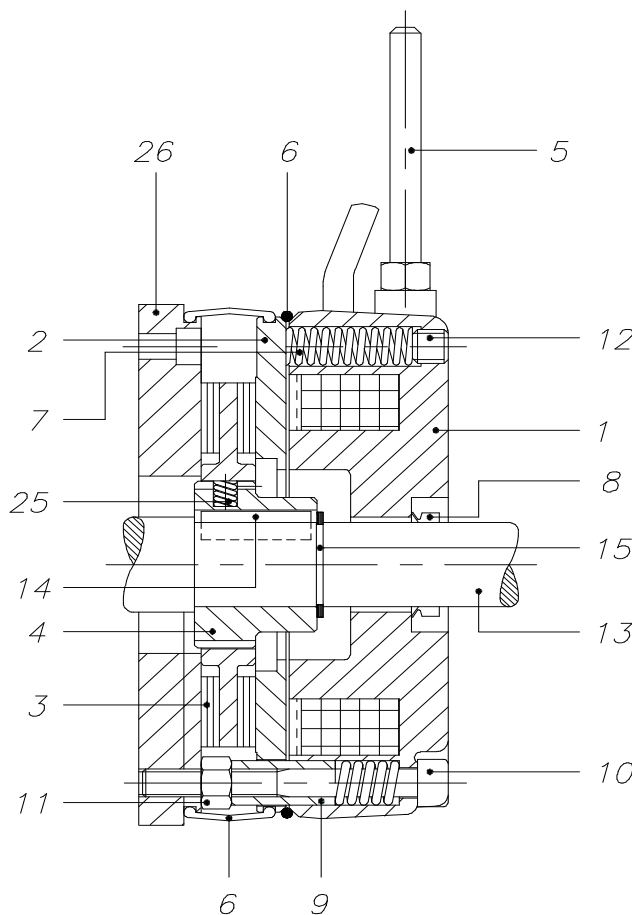

O.E.G. SPRING PRESSURE SAFETY BRAKES IN DIRECT CURRENT **FM TYPE** **TECHNICAL DATASHEET**

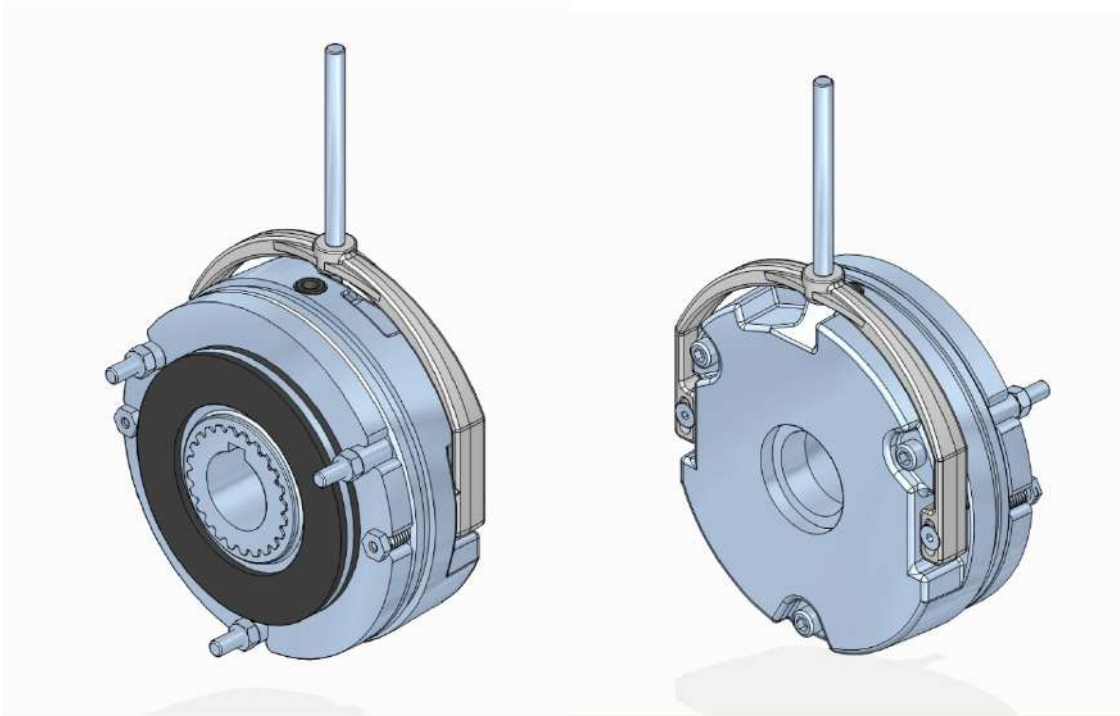

- 1 Magnet casing
- 2 Mobile anchor
- 3 Brake disc
- 4 Driving hub
- 5 Hand release lever (OPTIONAL)
- 6 Protection + "O" ring (OPTIONAL)
- 7 Thrust spring
- 8 "V" ring (OPTIONAL)
- 9 Guide pipe
- 10 Fastening screw
- 11 Locking nut
- 12 Brake torque adjusting screw (OPTIONAL)
- 13 Driving shaft
- 14 Key
- 15 Seeger ring
- 25 Antivibration 'O' ring
- 26 Driving flange (OPTIONAL)



The O.E.G. FM type brakes are safety brakes, since they act in the absence of power supply through the pressure exerted by springs. When the magnet case (1) is energized, the mobile anchor (2) is attracted, against the force of the springs (7), thus leaving it free to rotate the shaft (13), on which is mounted the brake disk (3) sliding axially on the splined hub (4). Disconnecting the power supply, the springs (7) push the mobile armature (2), sliding on the guides (9), pressing the brake disk (3) against the flange (26). In this way the shaft (13) is braked. The construction creates a softer redundancy making the equipment failsafe.

FEATURES

Braking torque from 5 Nm to 500 Nm.

Normal input voltage 103 V DC and 178 V DC from half-wave current rectifier (see "Electric accessories").

All voltages from 12 V DC to 300 V DC available on request.

S1 Service, Class F insulation, Class B over temperatures, IP55 protection (on request) for assembly under motor guard.

Asbestos-free noiseless friction packing.

Steel brake disc.

Steel driving hub with antivibration 'O' ring.

No axial load on the driving shaft.

Braking torque adjustable from 100% to 35%.

TYPICAL APPLICATION

Automations requiring a smooth intervention

Lifting and handling machines;

Transfer machines

Electric trucks.

Wind generator.

Gear motors with parallel or epicyclical axes.



DIMENSIONS

With reference to the drawing, see brake dimensions in the table.

Where present, the letter superscript indicates possible constructive alternatives that have to be considered coupled by apex (i.e. choosing C¹ means you have GA¹, X¹, Y¹, Z¹)

	02	03	04	05	06S	06	07	08	09
M_F[Nm]	5	10	20	40	70	100	150/200	300	500
A	30	35	42	50	50	65	74	90	90
B	65	75	85	102	124	133	153	182	212
C	4	5	6	8	8	12	12	14	14
C¹	5	6	8	8	8	12	14	14	14
D	36	41	48	56	56	76	84	105	105
E	88,5	101	115	135	160	170	190	230	264
F	12	15	20	25	30	40	40	45	50
F¹	15	20	25	30	30	40	45	45	50
G	40	50	60	65	85	85	114	125	145
GA	13,8	17,3	22,8	28,3	33,3	43,3	43,3	48,8	53,8
GA¹	17,3	22,8	28,3	33,3	33,3	43,3	47,8	48,8	53,8
H	40	45	51	59	67	68	75	91,5	106,5
K	88,5	101	115	135	160	170	190	230	264
I	78	88	100	120	140	150	170	206	238
L	20	20	23	26	35	35	35	51	64
M	14	18	23	28	33	43	43	52	52
M¹	17	23	28	33	33	43	48	52	52
N	3	3	3	3	3	3	6	6	6
P	M5	M5	M6	M6	M8	M8	M8	M10	M12
R	96	103	129	159,5	199	204	226	266	305
T	0,2	0,2	0,3	0,3	0,35	0,35	0,4	0,5	0,6
U	10	9	10	11	10	10	13	14	16
V	5	5	6	7	8	8	10	12	14
W	49	56	64	74,5	89	94	106	126	145
X	9	9	9	10	10	10	10,5	17	19
X¹	33	38	42	48	54	54	59	75,5	84
Y	1	1	1	1,25	1,25	1,25	1,5	1,5	1,5
Y¹	440	440	440	440	550	550	550	750	850
Z	43	48	54	62,5	71	72	79,5	97,5	111
Z¹	1	1	1	1	1,5	1,5	1,5	1,5	1,5
WEIGHT[daN]	1,5	2,2	3,1	4,9	8,3	9,5	12,3	24,8	36
P [W]	16	20	30	40	50	65	65	100	120



DRAWING

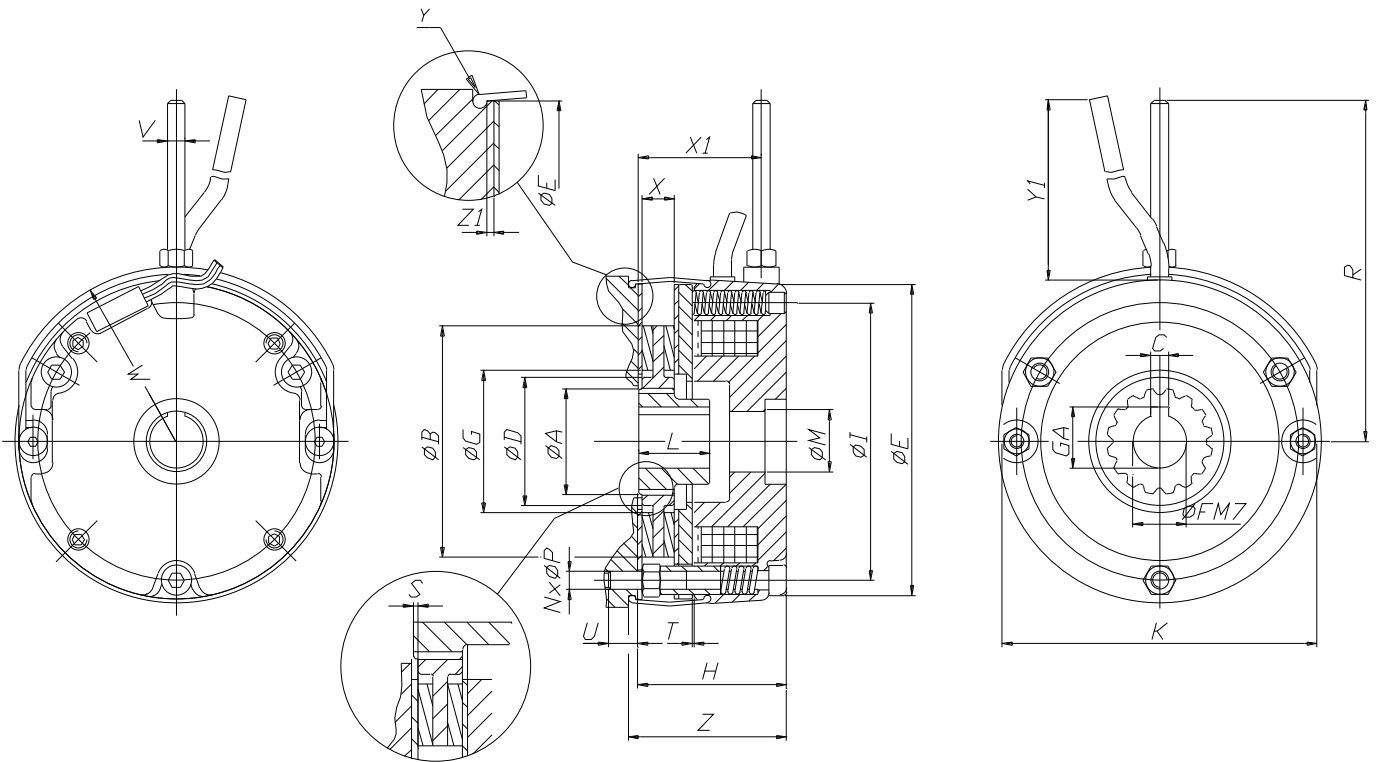



TECHNICAL INFORMATION

ONLY FOR FM (adjustable braking torque) series:

The chosen braking torque is obtained adjusting the regulation screws (12), on the back of the brake. Completely unscrewing does not allow braking torque falls below 35% safety value. Tightening the screws until in line with the back surface, the braking torque adju

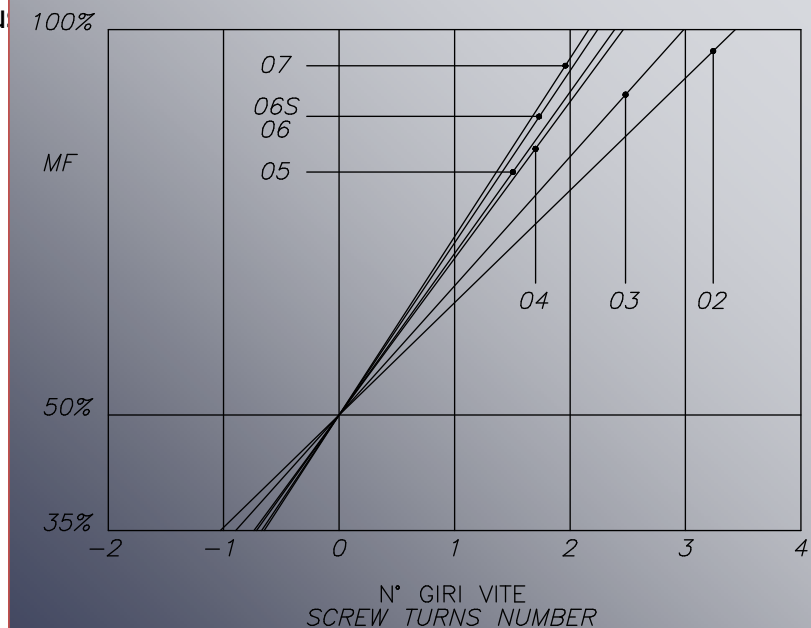
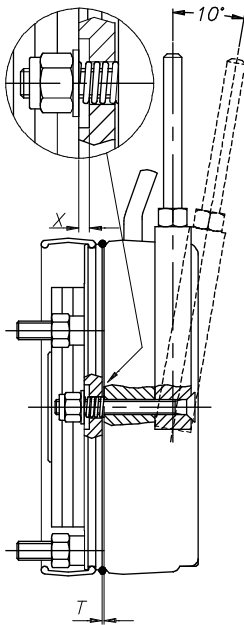

N.B. : CON LA VITE A FILO DEL CORPO MAGNETE LA COPPIA FRENANTE E' UGUALE AL 50%
N.B. : WITH THE SCREW FLUSH WITH THE MAGNET CASING , THE BRAKING TORQUE IS EQUAL TO 50%

FOR MV (fixed braking torque) series:

Braking torque can also be changed by step value removing springs.

Adjusting the braking torque to low values, allows the brake to release even with higher air-gaps than the adjustment X value for the manual release.

For safety reasons, the X value should be increased to a value that will not allow brake release with the adjustment value of the braking torque.

The lever rotation angle will increase accordingly.

When a patented safety release is mounted on the brake, adjusting the brake torque to lower values will not require any further operation.



ACCESSORY DEVICES

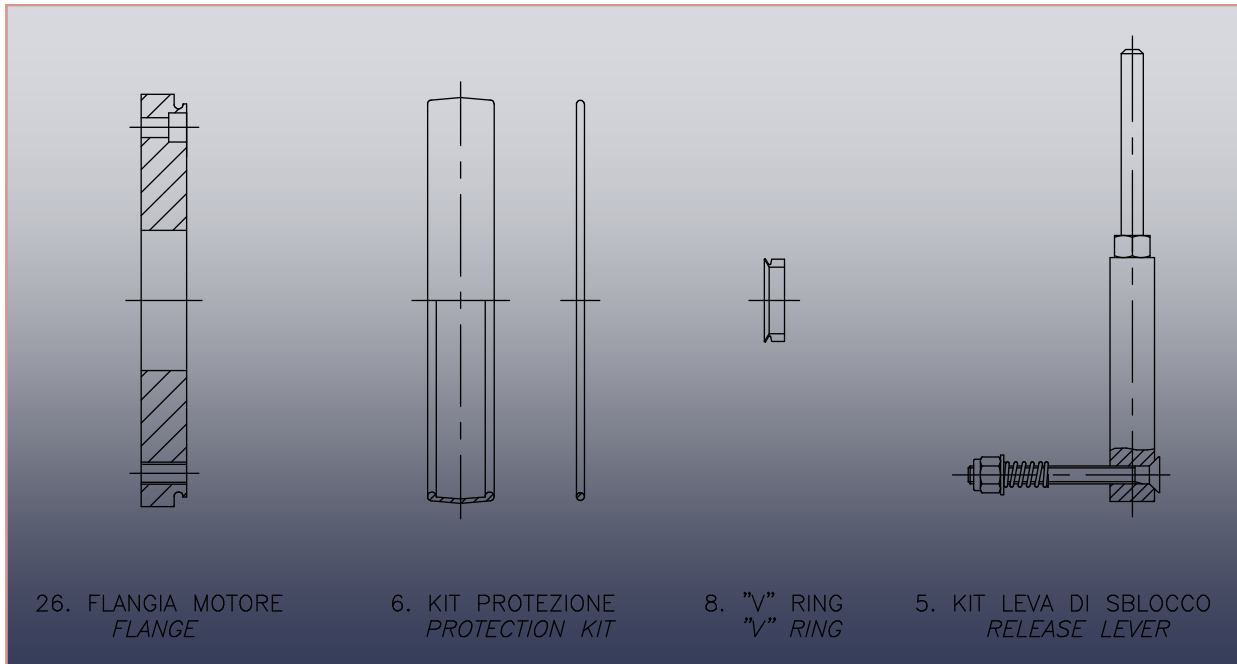

The accessory devices depicted above are present for the series of brakes.
For further details contact the manufacturer.



BRAKE SELECTION

Following table shows the parameter value for right brake selection.

		02	03	04	05	06S	06	07	08	09
Braking torque	M_F [Nm]	5	10	20	40	70	100	150	250	400
	T_{min} [mm]	0,2	0,2	0,3	0,3	0,35	0,35	0,4	0,5	0,5
Air Gap	T_{max} [mm]	0,5	0,5	0,6	0,6	0,7	0,7	0,8	1	1,2
	n_{max} [min ⁻¹]	3600	3600	3600	3600	3600	3000	3000	1500	1500
Release lever height	X [mm]	0,6	0,8	1	1	1,2	1,2	1,2	1,2	1,4
Brake disc moment of inertia	J [kgcm ²]	0,6	1,1	1,6	3,5	8,8	10,3	22,5	75	198
Brake life	$W^{1)_{tot}}$ [MJ]	260	370	500	750	1000	1100	1650	2700	4000
	$W^{2)_{2}}$ [MJ]	15,6	22,4	30	45	70	77	132	225	450
Braking time $t_1^{3)}$	[ms]	30	60	100	120	-	-	-	-	-
Braking time $t_1^{4)}$	[ms]	20	25	40	50	80	80	100	150	200
Release time $t_2^{5)}$	[ms]	100	120	150	220	300	200	200	300	450
Release time $t_2^{6)}$	[ms]	10	10	10	15	30	20	20	30	40

- 1) For friction packing wear up to a 1 mm thickness
- 2) Between two wear adjustments from T_{min} to T_{max}
- 3) With NBR rectifier
- 4) With SBR rectifier
- 5) Opening on AC side
- 6) Opening on DC side



BRAKE WORKING DIAGRAM FOR CALCULATIONS

